

**Constant voltage linear dimmable driver**  
**DGV Series suffix D(DALI-2+pushDIM+1-10V/10V PWM/Rx+12V)**

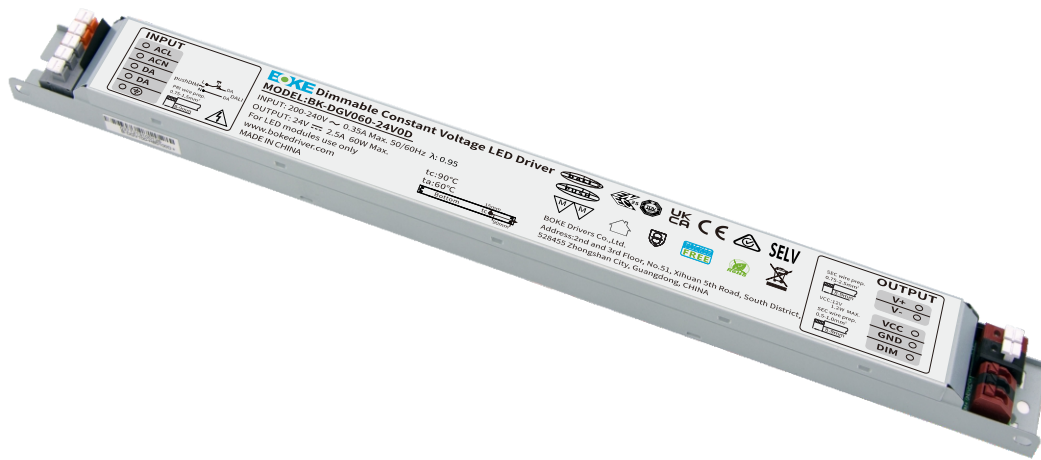

**Features**

- Support DALI-2/pushDIM+1-10V/10V PWM/Rx dimming +12V auxiliary power
- Provide 12V 100mA auxiliary power supply to power control module or sensor
- Soft dimming and flicker-free at any brightness
- Dimming range 1~100%,support multiple lights dimming
- Standby power input<0.5W, meets the requirements of ErP certification
- High PF, high efficiency, low THD
- SELV and Class I design, suitable for use inside of the light
- Compliance with CE, ENEC, UKCA, RCM, DALI-2 and other certifications
- IP20 protection grade, indoor use
- Nominal life-time up to 100,000 h
- 5-year guarantee

**Interfaces**

- DALI-2(DALI-2 DT6)
- PUSH(pushDIM)
- 1-10V 3in1(1-10V / 10V PWM/Rx)
- VCC Auxiliary power( 12V,100mA)

**Functions**

- Support self-contained emergency application
- Protective features (short-circuit, overload protection )

**Suitable for lights**

- Suitable for CV strip lights, CV linear lights, floor lights, three-proof lights, bracket lights, etc

**Typical applications**

- LED indoor lighting
- LED office lighting
- LED commercial lighting

**Model coding rules of DGV series**

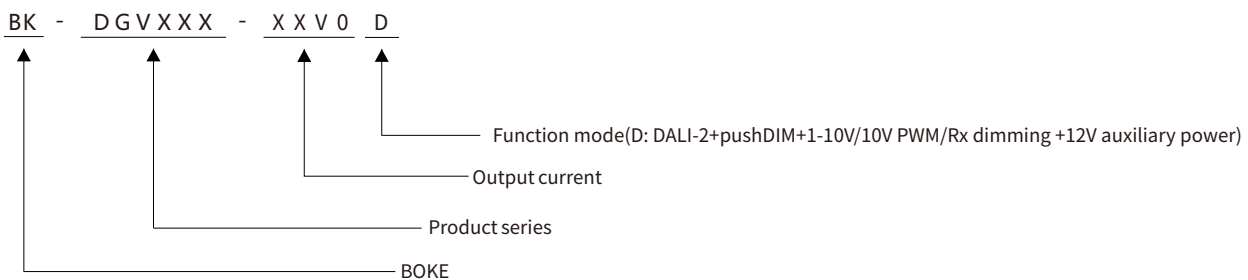

### Function list

Model	Suffix	Wired dimming			Aux power
		DALI-2	pushDIM	1-10V 3in1	12V/0.1A
BK-DGV036 BK-DGV060 BK-DGV100 BK-DGV150	D	√	√	√	√

### Model list

Model	Input voltage	Output power	Output voltage	Output current	Dimension	Certifications
BK-DGV036-24V0D	200-240VAC	36W MAX.	24VDC	1.5A	L245*W30*H21mm	CE, ENEC, UKCA, RCM, DALI-2, CCC
BK-DGV036-48V0D	200-240VAC	36W MAX.	48VDC	0.75A	L245*W30*H21mm	CE, ENEC, UKCA, RCM, DALI-2, CCC
BK-DGV060-24V0D	200-240VAC	60W MAX.	24VDC	2.5A	L285*W30*H21mm	CE, ENEC, UKCA, RCM, DALI-2, CCC
BK-DGV060-48V0D	200-240VAC	57.6W MAX.	48VDC	1.2A	L285*W30*H21mm	CE, ENEC, UKCA, RCM, DALI-2, CCC
BK-DGV100-24V0D	200-240VAC	100W MAX.	24VDC	4.2A	L355*W30*H21mm	CE, ENEC, UKCA, RCM, DALI-2, CCC
BK-DGV100-48V0D	200-240VAC	100W MAX.	48VDC	2.09A	L355*W30*H21mm	CE, ENEC, UKCA, RCM, DALI-2, CCC
BK-DGV150-24V0D	200-240VAC	150W MAX.	24VDC	6.25A	L355*W36*H23mm	CE, ENEC, UKCA, RCM, DALI-2, CCC
BK-DGV150-48V0D	200-240VAC	150W MAX.	48VDC	3.12A	L355*W36*H23mm	CE, ENEC, UKCA, RCM, DALI-2, CCC

**Technical data**

Product model	BK-DGV036-24V0D	BK-DGV036-48V0D	
<b>Output parameters</b>			
Regulation method	Constant voltage	Constant voltage	
Rated output current	1.5A	0.75A	
Rated output voltage	24V	48V	
Rated output power	36W Max	36W Max	
Output voltage adjustment	Fixed output	Fixed output	
Output current ripple LF	±2%	±2%	
Voltage accuracy	±4%	±4%	
Linear regulation	±4%	±4%	
Load regulation	±4%	±4%	
Flicker-free	Pst LM=0.002, SVM=0.000,(The above parameters are obtained by testing with constant voltage light strip)		
<b>Input parameters</b>			
Rated input voltage range	200-240VAC		
Input voltage range	180-264VAC		
Input voltage shock	<380 VAC		
Input current	<0.25A (AC 200V)		
Input frequency	50/60Hz		
Input PF/Input DF	PF: 0.98,DF: 0.99,see the electrical values below for details		
Input THD	7%,see the electrical values below for details		
Efficiency(Max)	88.5% (230V AC & Full load),see the electrical values below for details		
In-rush current	16.25A peak ,260us duration(50 % Ipeak), see the description below for details		
Start/Switchover/Turn off	<0.7s(AC start),<0.7s(DC start),<0.3s(AC/DC switchover),<0.5s(Turn off )		
Switching cycles	> 50,000 switching cycles		
Power consumption	Full load(Pin):40.7W, No load(Pno): N/A, On stand-by(Psb) : <0.5W, Network stand-by(Pnet) : N/A		
<b>Safety</b>			
Withstand voltage	I/P-O/P(LED):3750VAC,I/P-FG:1750VAC,O/P-FG:500VAC,I/P-DALI: 1500VAC,O/P-DALI: 1500VAC		
Mains surge capability	L-N:2KV,L-FG/N-FG:2KV(Performance criterion:A)		
Leakage current	0.48mA (230V AC & Full load)		
Isolation resistance	I/P-O/P:100MΩ/500Vdc/25°C/70% RH		
<b>Control interface</b>			
DALI dimming port	Voltage range: DC9.5-22.5V, typical 16V, interface current consumption: 1.8mA		
pushDIM dimming port	Voltage range: AC180-264V 50/60Hz		
1-10V 3in1 dimming port	Voltage range: DC0-15V, maximum output current ≤0.75mA		
Auxiliary power supply	DC12V ±5% 100mA		
Dimming range	1-100%		
Dimming drive mode	H-PWM		
<b>Emergency support</b>			
Central emergency system	Not supported		
Self-contained emergency	Supported		
<b>Environment &amp; Life time</b>			
Operating temperature	Ta=-20-60°C		
Case temperature	Tc=90°C		
Operating humidity	5-85% RH, not condensing		
Storage temp./humidity	-40-80°C, 5-85% RH, not condensing		
IP grade	IP20		
MTBF	500,000H,MIL-HDBK-217F(25°C)		
Life-time	Nominal life-time up to 100,000 h, see the description below for details		
Vibration resistant	10~500Hz,5G 12min./1cycle,period for 72min. each along X,Y,Z axes		
Acoustic Noise	<25dB(30cm, Normal operation)		
Environmental protection	RoHS		
<b>Certifications and standards</b>			
Certification	CE, ENEC, UKCA, RCM, DALI-2, CCC		
Safety	EN61347-1, EN61347-2-13, EN62384		
EMC	EN55015, EN61000-3-2, EN61000-3-3, EN61000-4-2,3,4,5,6,8,11, EN61547		
DALI-2	IEC 62386-101(DALI-2), IEC 62386-102(DALI-2), IEC 62386-207(DALI-2)		
EL	N/A		
RF	N/A		

**Remarks**

1.By default, all parameter are measured at 230VAC input, full load and 25°C of ambient temperature.

## Technical data

Product model	BK-DGV060-24V0D	BK-DGV060-48V0D	
<b>Output parameters</b>			
Regulation method	Constant voltage	Constant voltage	
Rated output current	2.5A	1.2A	
Rated output voltage	24V	48V	
Rated output power	60W Max	57.6W Max	
Output voltage adjustment	Fixed output	Fixed output	
Output current ripple LF	±2%	±2%	
Voltage accuracy	±4%	±4%	
Linear regulation	±4%	±4%	
Load regulation	±4%	±4%	
Flicker-free	Pst LM=0.176, SVM=0.000,(The above parameters are obtained by testing with constant voltage light strip)		
<b>Input parameters</b>			
Rated input voltage range	200-240VAC		
Input voltage range	180-264VAC		
Input voltage shock	<380 VAC		
Input current	<0.35A (AC200V)		
Input frequency	50/60Hz		
Input PF/Input DF	PF: 0.98,DF: 0.99,see the electrical values below for details		
Input THD	7%,see the electrical values below for details		
Efficiency(Max)	90% (230V AC & Full load),see the electrical values below for details		
In-rush current	34A peak ,260us duration(50 % Ipeak), see the description below for details		
Start/Switchover/Turn off	<0.7s(AC start),<0.7s(DC start),<0.3s(AC/DC switchover),<0.5s(Turn off )		
Switching cycles	> 50,000 switching cycles		
Power consumption	Full load(Pin):66.7W, No load(Pno): N/A, On stand-by(Psb) : <0.5W, Network stand-by(Pnet) : N/A		
<b>Safety</b>			
Withstand voltage	I/P-O/P(LED):3750VAC,I/P-FG:1750VAC,O/P-FG:500VAC,I/P-DALI: 1500VAC,O/P-DALI: 1500VAC		
Mains surge capability	L-N:2KV,L-FG/N-FG:2KV(Performance criterion:A)		
Leakage current	0.46mA (230V AC & Full load)		
Isolation resistance	I/P-O/P:100MΩ/500Vdc/25°C/70% RH		
<b>Control interface</b>			
DALI dimming port	Voltage range: DC9.5-22.5V, typical 16V, interface current consumption: 1.8mA		
pushDIM dimming port	Voltage range: AC180-264V 50/60Hz		
1-10V 3in1 dimming port	Voltage range: DC0-15V, maximum output current ≤0.75mA		
Auxiliary power supply	DC12V ±5% 100mA		
Dimming range	1-100%		
Dimming drive mode	H-PWM		
<b>Emergency support</b>			
Central emergency system	Not supported		
Self-contained emergency	Supported		
<b>Environment &amp; Life time</b>			
Operating temperature	Ta=-20-60°C		
Case temperature	Tc=90°C		
Operating humidity	5-85% RH, not condensing		
Storage temp./humidity	-40-80°C, 5-85% RH, not condensing		
IP grade	IP20		
MTBF	500,000H,MIL-HDBK-217F(25°C)		
Life-time	Nominal life-time up to 100,000 h, see the description below for details		
Vibration resistant	10~500Hz,5G 12min./1cycle,period for 72min. each along X,Y,Z axes		
Acoustic Noise	<25dB(30cm, Normal operation)		
Environmental protection	RoHS		
<b>Certifications and standards</b>			
Certification	CE, ENEC, UKCA, RCM, DALI-2, CCC		
Safety	EN61347-1, EN61347-2-13, EN62384		
EMC	EN55015, EN61000-3-2, EN61000-3-3, EN61000-4-2,3,4,5,6,8,11, EN61547		
DALI-2	IEC 62386-101(DALI-2), IEC 62386-102(DALI-2), IEC 62386-207(DALI-2)		
EL	N/A		
RF	N/A		

## Remarks

1.By default, all parameter are measured at 230VAC input, full load and 25°C of ambient temperature.

## Technical data

Product model	BK-DGV100-24V0D	BK-DGV100-48V0D	
<b>Output parameters</b>			
Regulation method	Constant voltage	Constant voltage	
Rated output current	4.2A	2.09A	
Rated output voltage	24V	48V	
Rated output power	100W Max	100W Max	
Output voltage adjustment	Fixed output	Fixed output	
Output current ripple LF	±2%	±2%	
Voltage accuracy	±4%	±4%	
Linear regulation	±4%	±4%	
Load regulation	±4%	±4%	
Flicker-free	Pst LM=0.065, SVM=0.015,(The above parameters are obtained by testing with constant voltage light strip)		
<b>Input parameters</b>			
Rated input voltage range	200-240VAC		
Input voltage range	180-264VAC		
Input voltage shock	<300 V AC		
Input current	<0.65A (AC 200V)		
Input frequency	50/60Hz		
Input PF/Input DF	PF: 0.99,DF: 0.99,see the electrical values below for details		
Input THD	5%,see the electrical values below for details		
Efficiency(Max)	92% (230V AC & Full load),see the electrical values below for details		
In-rush current	46.38A peak ,278us duration(50 % Ipeak), see the description below for details		
Start/Switchover/Turn off	<0.7s(AC start),<0.7s(DC start),<0.3s(AC/DC switchover),<0.5s(Turn off )		
Switching cycles	> 50,000 switching cycles		
Power consumption	Full load(Pin):108.7W, No load(Pno): N/A, On stand-by(Psb) : <0.5W, Network stand-by(Pnet) : N/A		
<b>Safety</b>			
Withstand voltage	I/P-O/P(LED):3750VAC,I/P-FG:1750VAC,O/P-FG:500VAC,I/P-DALI: 1500VAC,O/P-DALI: 1500VAC		
Mains surge capability	L-N:2KV,L-FG/N-FG:2KV(Performance criterion:B)		
Leakage current	0.45mA (230V AC & Full load)		
Isolation resistance	I/P-O/P:100MΩ/500Vdc/25°C/70% RH		
<b>Control interface</b>			
DALI dimming port	Voltage range: DC9.5-22.5V, typical 16V, interface current consumption: 1.8mA		
pushDIM dimming port	Voltage range: AC180-264V 50/60Hz		
1-10V 3in1 dimming port	Voltage range: DC0-15V, maximum output current ≤0.75mA		
Auxiliary power supply	DC12V ±5% 100mA		
Dimming range	1-100%		
Dimming drive mode	H-PWM		
<b>Emergency support</b>			
Central emergency system	Not supported		
Self-contained emergency	Supported		
<b>Environment &amp; Life time</b>			
Operating temperature	Ta=-20-60°C		
Case temperature	Tc=95°C		
Operating humidity	5-85% RH, not condensing		
Storage temp./humidity	-40-80°C, 5-85% RH, not condensing		
IP grade	IP20		
MTBF	500,000H,MIL-HDBK-217F(25°C)		
Life-time	Nominal life-time up to 100,000 h, see the description below for details		
Vibration resistant	10~500Hz,5G 12min./1cycle,period for 72min. each along X,Y,Z axes		
Acoustic Noise	<25dB(30cm, Normal operation)		
Environmental protection	RoHS		
<b>Certifications and standards</b>			
Certification	CE, ENEC, UKCA, RCM, DALI-2, CCC		
Safety	EN61347-1, EN61347-2-13, EN62384		
EMC	EN55015, EN61000-3-2 , EN61000-3-3, EN61000-4-2,3,4,5,6,8,11, EN61547		
DALI-2	IEC 62386-101(DALI-2), IEC 62386-102(DALI-2), IEC 62386-207(DALI-2)		
EL	N/A		
RF	N/A		

## Remarks

1.By default, all parameter are measured at 230VAC input, full load and 25°C of ambient temperature.

## Technical data

Product model	BK-DGV150-24V0D	BK-DGV150-48V0D	
<b>Output parameters</b>			
Regulation method	Constant voltage	Constant voltage	
Rated output current	6.25A	3.12A	
Rated output voltage	24V	48V	
Rated output power	150W Max	150W Max	
Output voltage adjustment	Fixed output	Fixed output	
Output current ripple LF	±2%	±2%	
Voltage accuracy	±4%	±4%	
Linear regulation	±4%	±4%	
Load regulation	±4%	±4%	
Flicker-free	Pst LM=0.018, SVM=0.000,(The above parameters are obtained by testing with constant voltage light strip)		
<b>Input parameters</b>			
Rated input voltage range	200-240VAC		
Input voltage range	180-264VAC		
Input voltage shock	<300 V AC		
Input current	<1A (AC 200V)		
Input frequency	50/60Hz		
Input PF/Input DF	PF: 0.99,DF: 0.99,see the electrical values below for details		
Input THD	5%,see the electrical values below for details		
Efficiency(Max)	92% (230V AC & Full load),see the electrical values below for details		
In-rush current	50A peak,468us duration(50 % Ipeak), see the description below for details		
Start/Switchover/Turn off	<0.7s(AC start),<0.7s(DC start),<0.3s(AC/DC switchover),<0.5s(Turn off )		
Switching cycles	> 50,000 switching cycles		
Power consumption	Full load(Pin):162.2W, No load(Pno): N/A, On stand-by(Psb) : <0.5W, Network stand-by(Pnet) : N/A		
<b>Safety</b>			
Withstand voltage	I/P-O/P(LED):3750VAC,I/P-FG:1750VAC,O/P-FG:500VAC,I/P-DALI: 1500VAC,O/P-DALI: 1500VAC		
Mains surge capability	L-N:2KV,L-FG/N-FG:2KV(Performance criterion:B)		
Leakage current	0.38mA (230V AC & Full load)		
Isolation resistance	I/P-O/P:100MΩ/500Vdc/25°C/70% RH		
<b>Control interface</b>			
DALI dimming port	Voltage range: DC9.5-22.5V, typical 16V, interface current consumption: 1.8mA		
pushDIM dimming port	Voltage range: AC180-264V 50/60Hz		
1-10V 3in1 dimming port	Voltage range: DC0-15V, maximum output current ≤0.75mA		
Auxiliary power supply	DC12V ±5% 100mA		
Dimming range	1-100%		
Dimming drive mode	H-PWM		
<b>Emergency support</b>			
Central emergency system	Not supported		
Self-contained emergency	Supported		
<b>Environment &amp; Life time</b>			
Operating temperature	Ta=-20-60°C		
Case temperature	Tc=90°C		
Operating humidity	5-85% RH, not condensing		
Storage temp./humidity	-40-80°C, 5-85% RH, not condensing		
IP grade	IP20		
MTBF	500,000H,MIL-HDBK-217F(25°C)		
Life-time	Nominal life-time up to 100,000 h, see the description below for details		
Vibration resistant	10~500Hz,5G 12min./1cycle,period for 72min. each along X,Y,Z axes		
Acoustic Noise	<25dB(30cm, Normal operation)		
Environmental protection	RoHS		
<b>Certifications and standards</b>			
Certification	CE, ENEC, UKCA, RCM, DALI-2, CCC		
Safety	EN61347-1, EN61347-2-13, EN62384		
EMC	EN55015, EN61000-3-2, EN61000-3-3, EN61000-4-2,3,4,5,6,8,11, EN61547		
DALI-2	IEC 62386-101(DALI-2), IEC 62386-102(DALI-2), IEC 62386-207(DALI-2)		
EL	N/A		
RF	N/A		

## Remarks

1.By default, all parameter are measured at 230VAC input, full load and 25°C of ambient temperature.

**Electrical values**

**BK-DGV036-24V0D**

Efficiency vs load

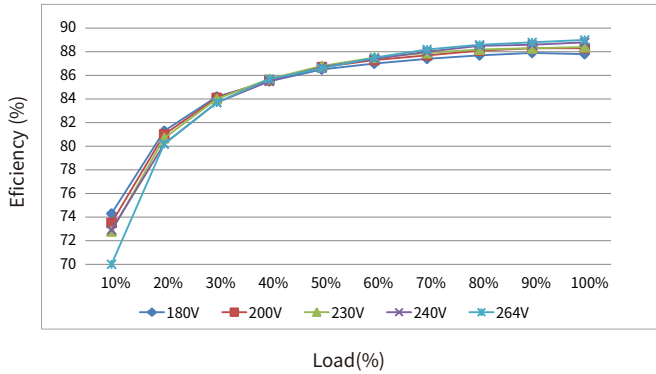

THD vs. Load

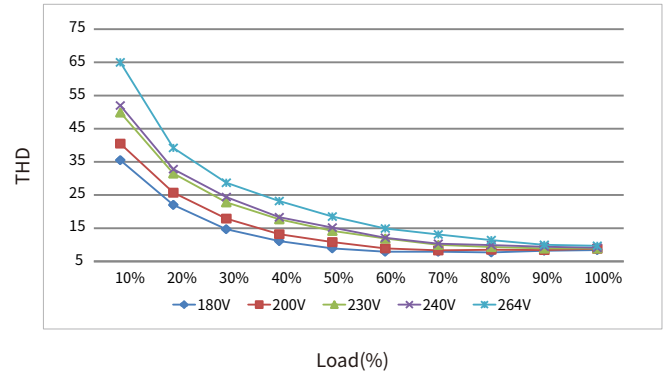

Power factor vs. Load

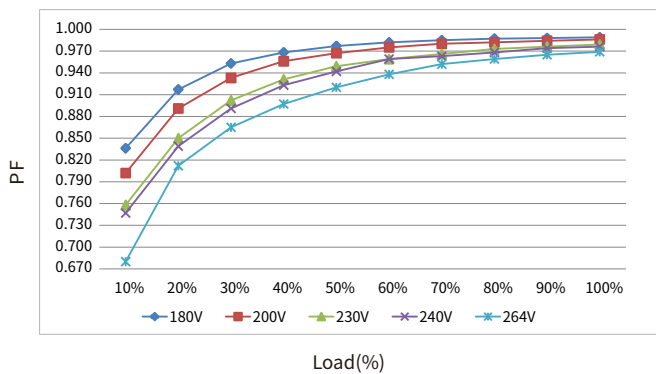

displacement power vs. Load

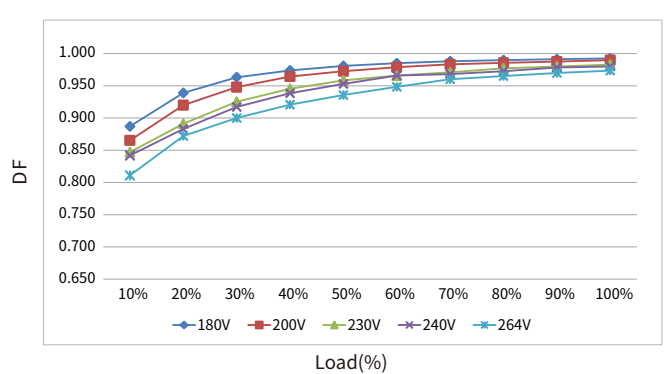

**BK-DGV036-48V0D**

Efficiency vs load

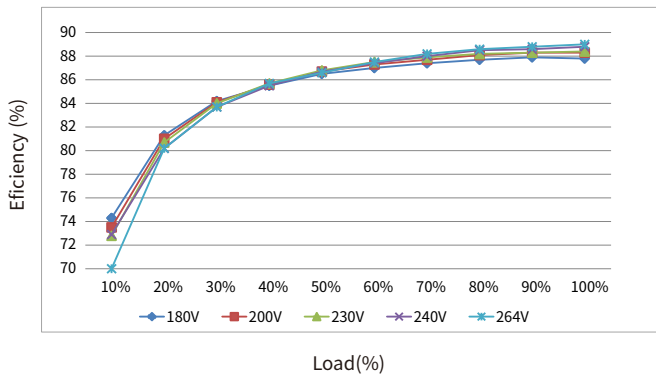

THD vs. Load

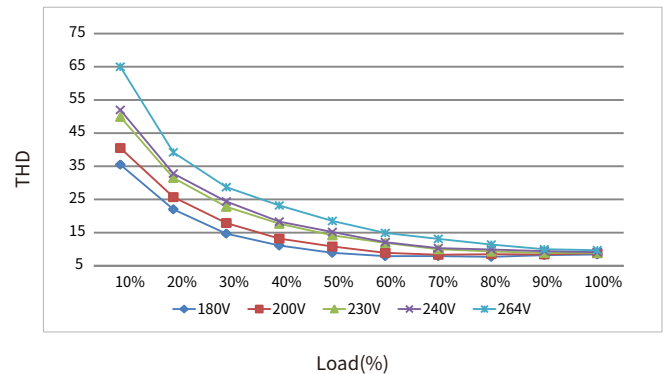

Power factor vs. Load

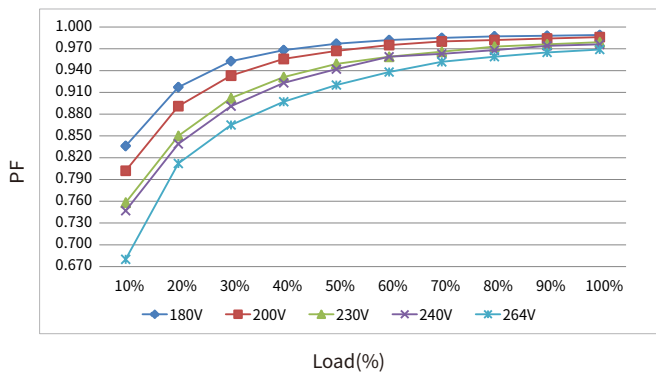

displacement power vs. Load

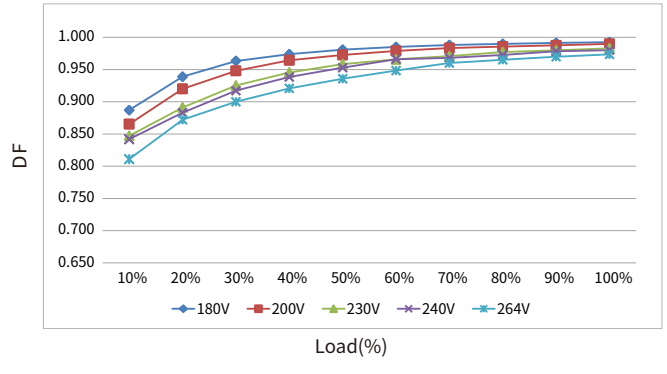

Electrical values

**BK-DGV060-24V0D**

Efficiency vs load

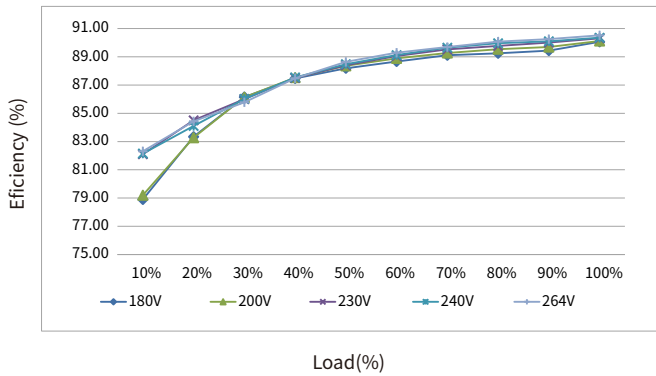

THD vs. Load

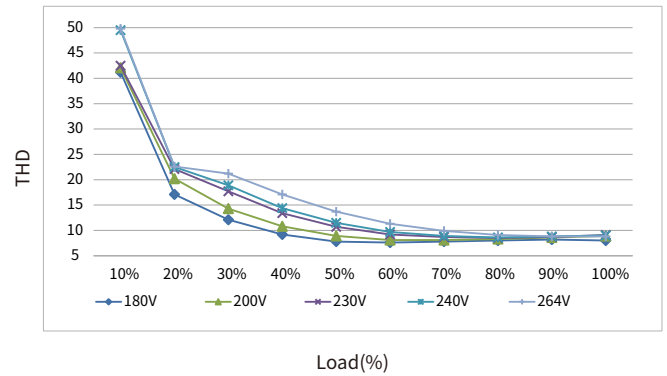

Power factor vs. Load

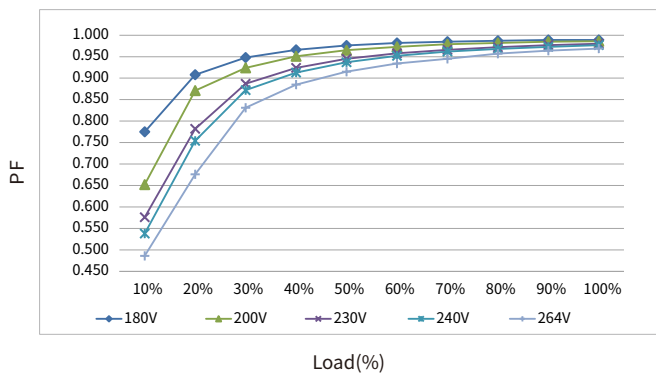

displacement power vs. Load

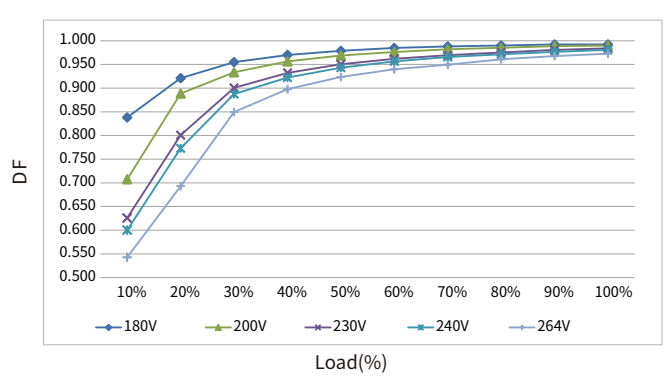

**BK-DGV060-48V0D**

Efficiency vs load

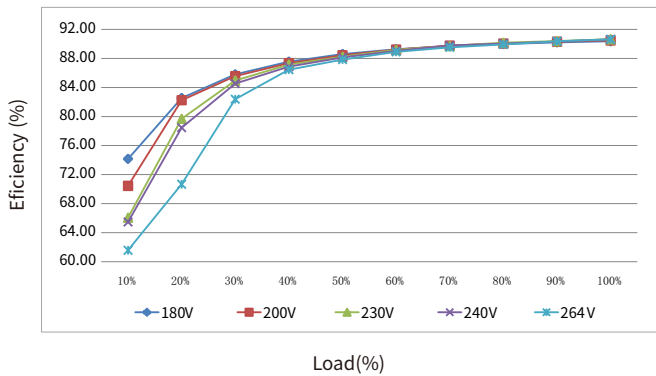

THD vs. Load

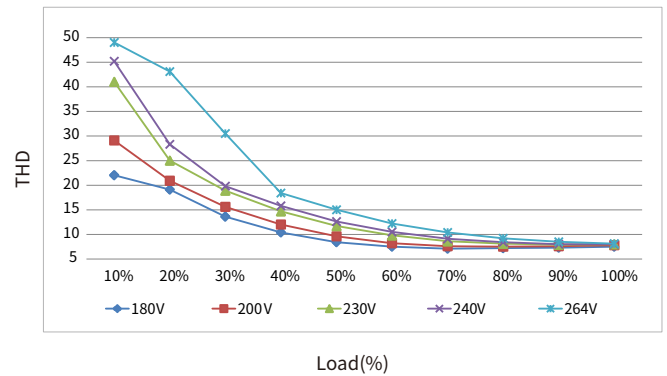

Power factor vs. Load

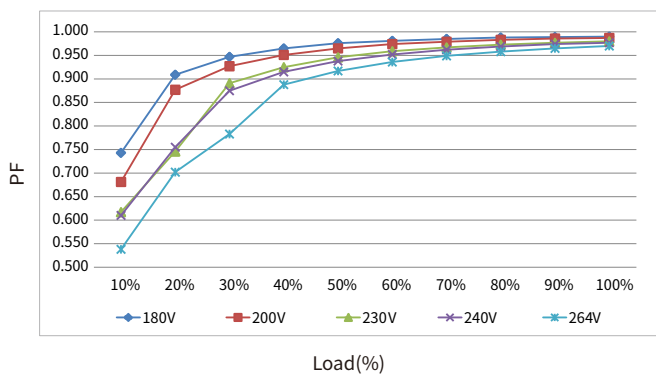

displacement power vs. Load

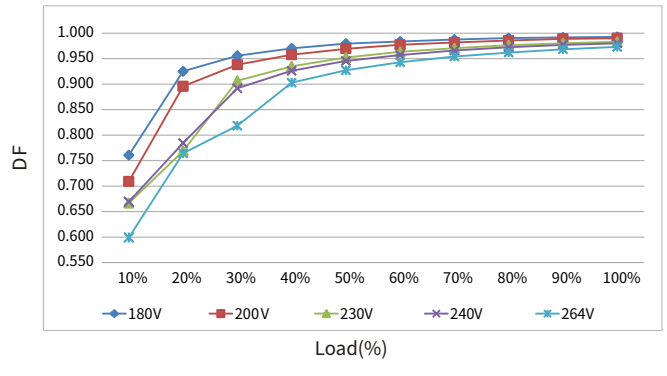

Electrical values

**BK-DGV100-24V0D**

Efficiency vs load

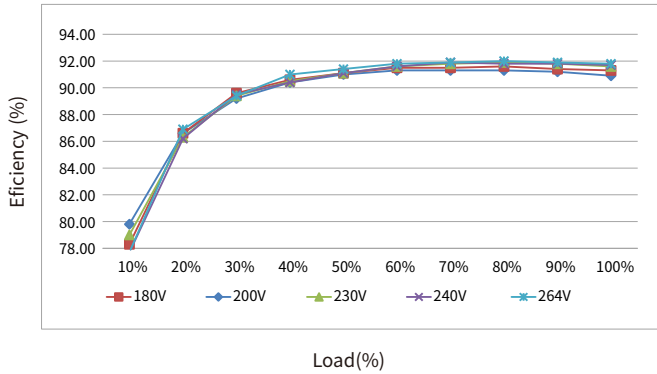

THD vs. Load

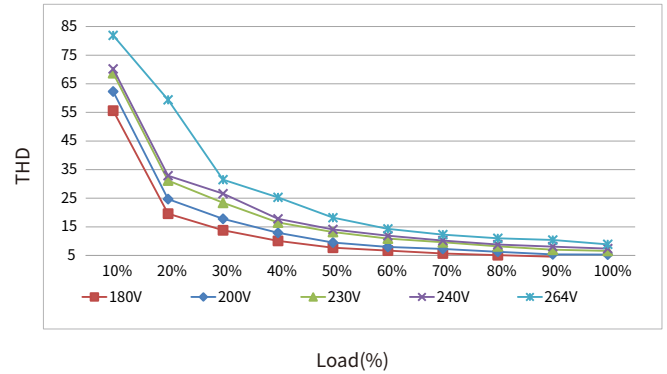

Power factor vs. Load

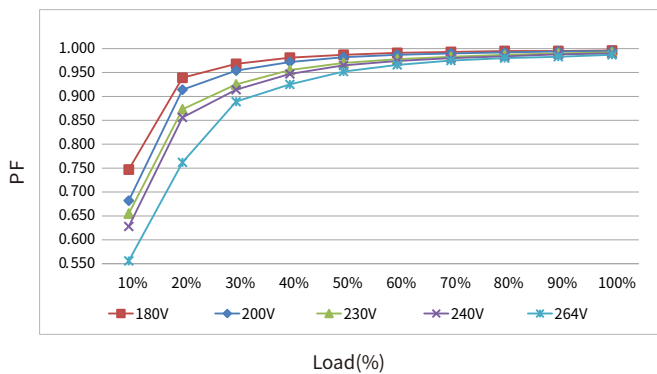

displacement power vs. Load

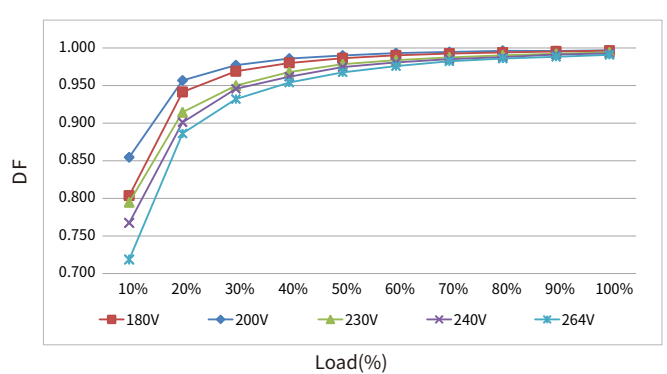

**BK-DGV100-48V0D**

Efficiency vs load

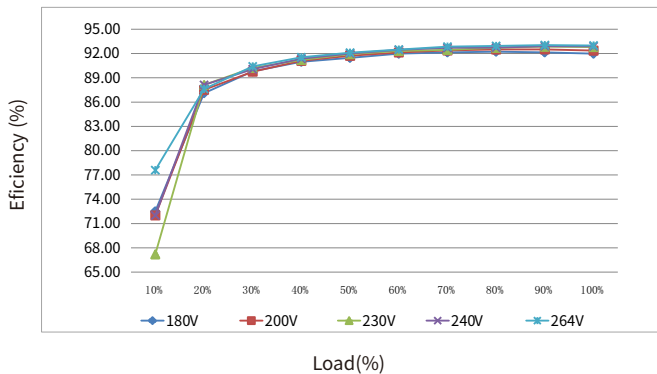

THD vs. Load

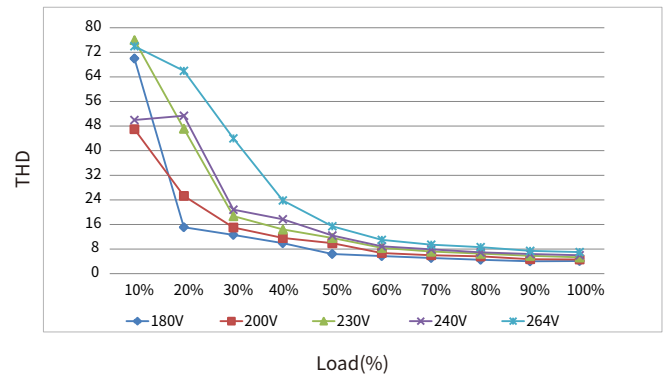

Power factor vs. Load

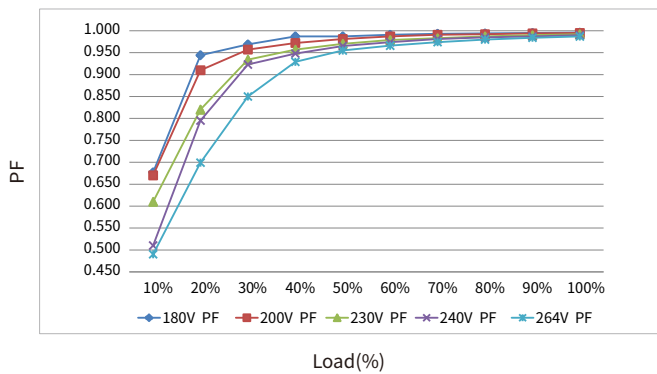

displacement power vs. Load

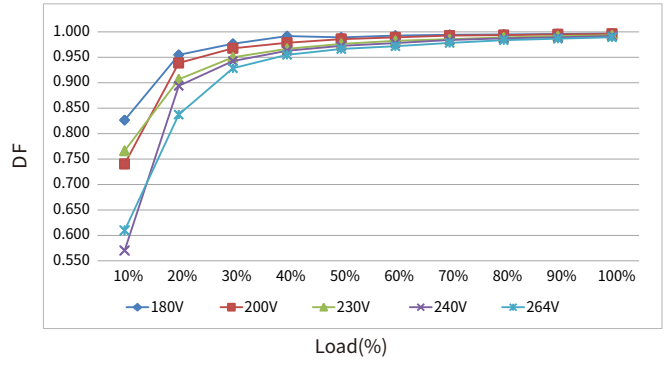

Electrical values

**BK-DGV150-24V0D**

Efficiency vs load

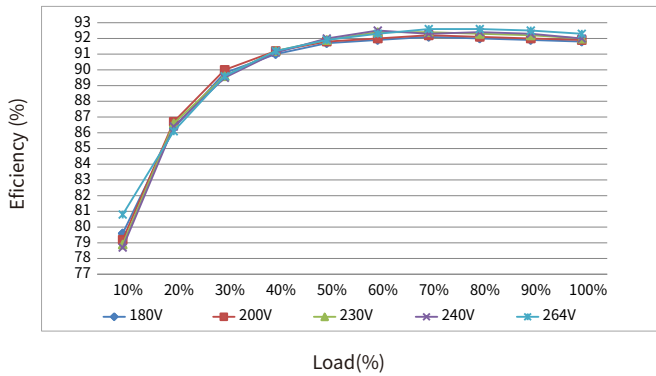

THD vs. Load

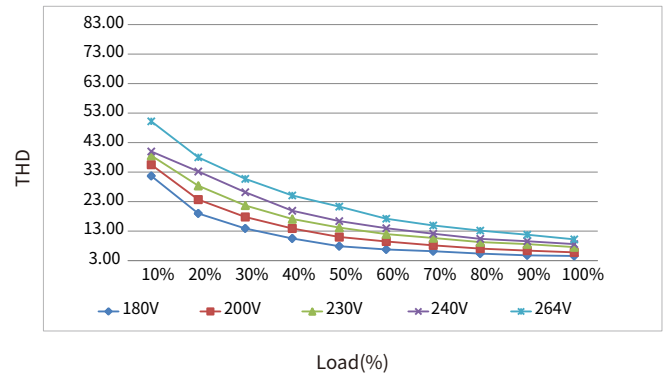

Power factor vs. Load

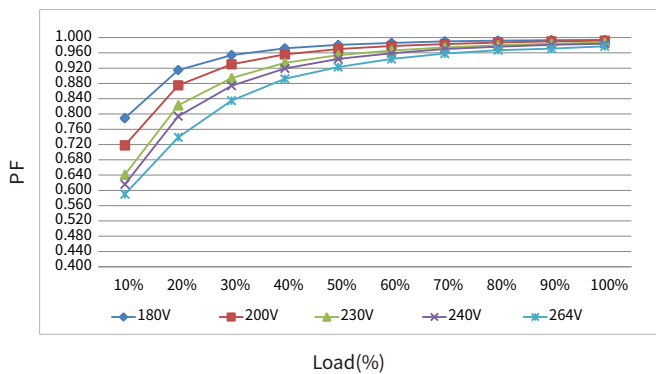

displacement power vs. Load

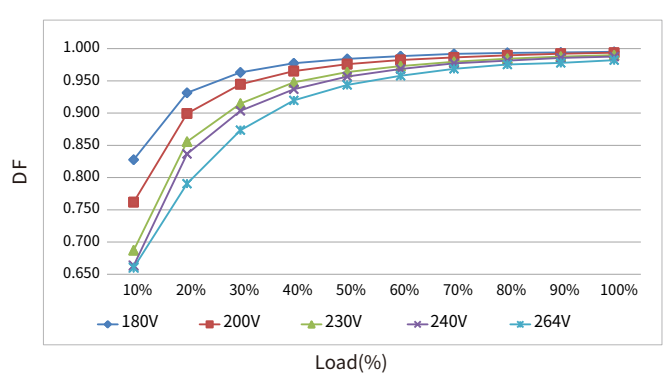

**BK-DGV150-48V0D**

Efficiency vs load

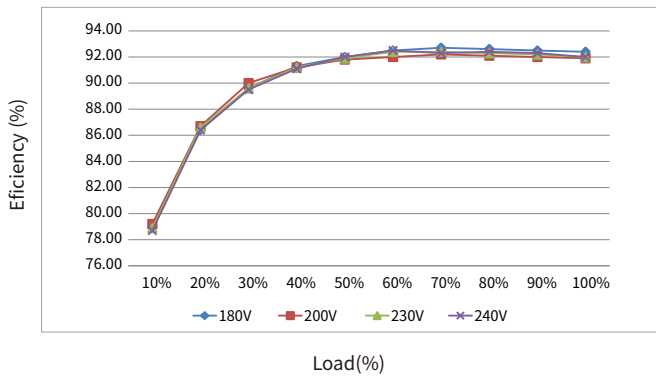

THD vs. Load

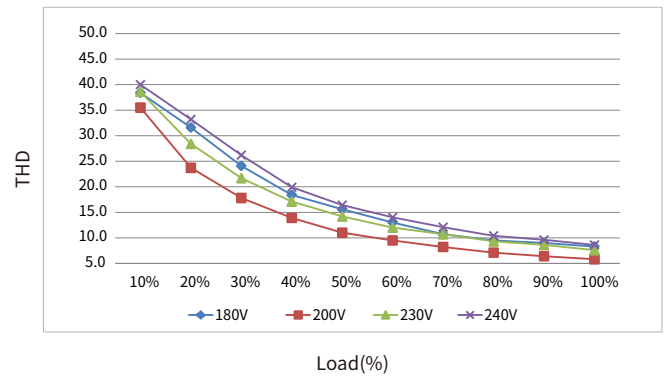

Power factor vs. Load

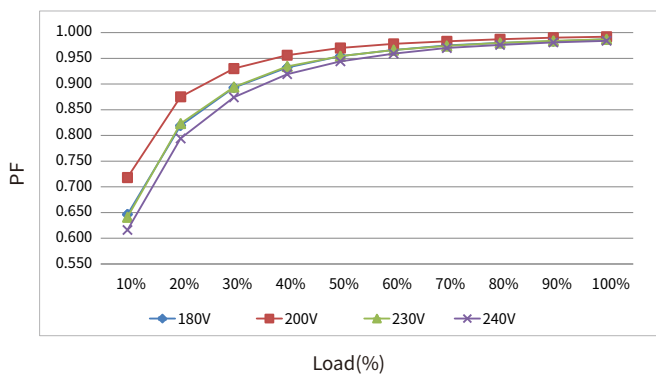

displacement power vs. Load

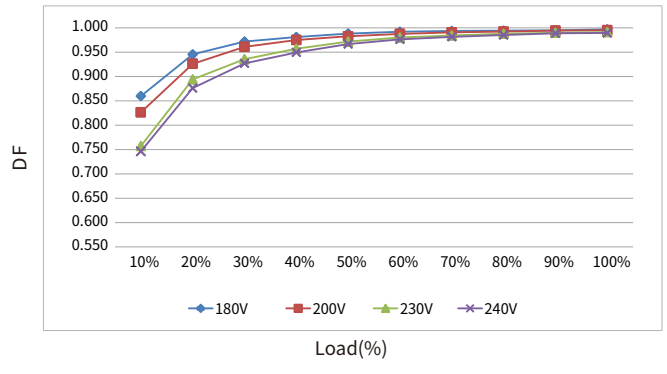

**Expected life-time**

**BK-DGV036**

Life-time vs. case temperature

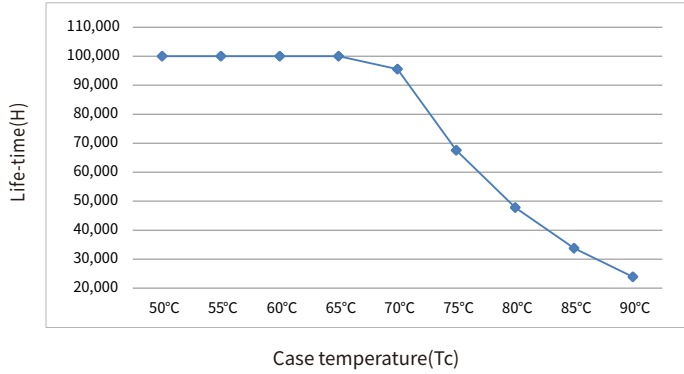

**BK-DGV060**

Life-time vs. case temperature

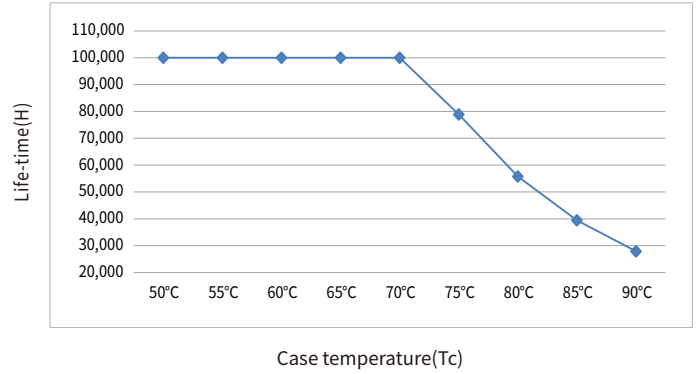

**BK-DGV100**

Life-time vs. case temperature

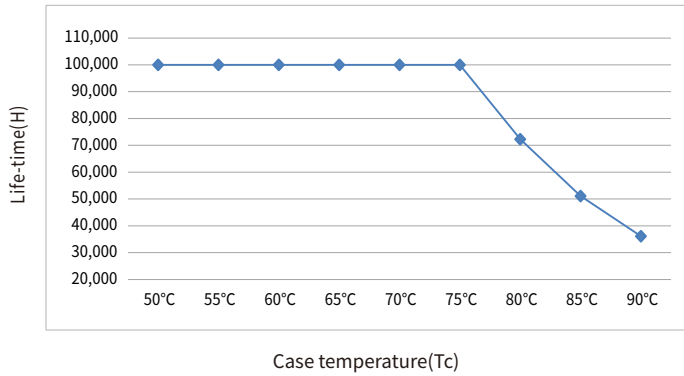

**BK-DGV150**

Life-time vs. case temperature

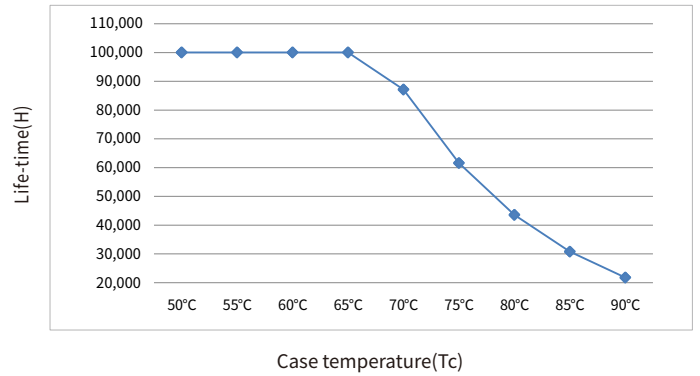

- The life-time of the LED driver is shown in the figure above (calculated based on the 90% survival rate).
- The relation of tc to ta temperature depends also on the luminaire design.

**Surge**

Model	Ipeak	Twidth	Condition	Relative number of MCB/pcs															
				B10	B13	B16	B20	B25	C10	C13	C16	C20	C25	D10	D13	D16	D20	D25	
BK-DGV036	16.25A	260us	AC 230V, Full load, Cold start, Ta ≤ 30°C, MCB is not installed side by side	14	18	23	28	36	24	31	38	47	59	38	50	61	76	95	
BK-DGV060	34A	260us		7	9	11	14	17	11	15	18	23	28	23	29	36	45	57	
BK-DGV100	46.38A	278us		4	6	7	9	11	7	9	12	14	18	14	19	23	29	36	
BK-DGV150	50A	468us		2	3	4	5	6	4	5	6	8	9	8	10	12	15	19	

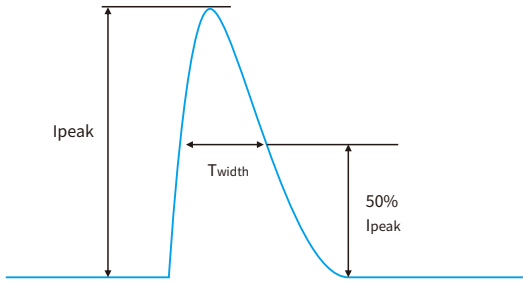

**Remarks**

- The number of drives mounted under different MCBs in the table is the maximum value. Please do not exceed this number during installation.
- Calculation uses typical values from ABB series S200 as a reference.
- Different brands and models of miniature circuit breakers, the number of drives mounted will be slightly different.
- If the ambient temperature of the MCB installation exceeds 30°C or multiple MCBs are installed side by side, the number of drives mounted will be reduced and the calculation needs to be recalculated.
- Electrician's usually consider Type B for household lighting and Type C for commercial lighting application.

**Functions**

**Output short-circuit protection**

- When the output of the driver is short-circuited, the driver will enter the protection state, disconnect the AC for more than 1 minute, and the output will return to normal.

**Output overload protection**

- When the load connected to the driver exceeds the rated power, the driver will enter a hiccup state. After reducing the load power, the driver will resume normal output.

**Insulation between circuits**

Isolation	Input	Output	Case	DALI	PUSH	PWM	VCC
Input	-	Double	Basic	Basic	-	Double	Double
Output	Double	-	Basic	Basic	Double	-	-
Case	Basic	Basic	-	Basic	Basic	Basic	Basic

Label

DGV036

<b>INPUT</b> <input type="radio"/> ACL <input type="radio"/> ACN <input type="radio"/> DA <input type="radio"/> DA <input type="radio"/> DA <input type="radio"/> DA 	<b>BOKE Dimmable Constant Voltage LED Driver</b> <b>MODEL: BK-DGV036-24V0D</b> INPUT: 200-240V ~ 0.25A Max. 50/60Hz λ: 0.95 OUTPUT: 24V = 1.5A 36W Max. For LED modules use only www.bokedriver.com MADE IN CHINA		<b>OUTPUT</b> <input type="radio"/> V+ <input type="radio"/> V- <input type="radio"/> VCC <input type="radio"/> GND <input type="radio"/> DIM
	tc:90°C ta:60°C BOKE Drivers Co.,Ltd. Address:2nd and 3rd Floor, No.51, Xihuan 5th Road, South District, 528455 Zhongshan City, Guangdong, CHINA		

<b>INPUT</b> <input type="radio"/> ACL <input type="radio"/> ACN <input type="radio"/> DA <input type="radio"/> DA <input type="radio"/> DA <input type="radio"/> DA 	<b>BOKE Dimmable Constant Voltage LED Driver</b> <b>MODEL: BK-DGV036-48V0D</b> INPUT: 200-240V ~ 0.25A Max. 50/60Hz λ: 0.95 OUTPUT: 48V = 0.75A 36W Max. For LED modules use only www.bokedriver.com MADE IN CHINA		<b>OUTPUT</b> <input type="radio"/> V+ <input type="radio"/> V- <input type="radio"/> VCC <input type="radio"/> GND <input type="radio"/> DIM
	tc:90°C ta:60°C BOKE Drivers Co.,Ltd. Address:2nd and 3rd Floor, No.51, Xihuan 5th Road, South District, 528455 Zhongshan City, Guangdong, CHINA		

DGV060

<b>INPUT</b> <input type="radio"/> ACL <input type="radio"/> ACN <input type="radio"/> DA <input type="radio"/> DA <input type="radio"/> DA <input type="radio"/> DA 	<b>BOKE Dimmable Constant Voltage LED Driver</b> <b>MODEL: BK-DGV060-24V0D</b> INPUT: 200-240V ~ 0.35A Max. 50/60Hz λ: 0.95 OUTPUT: 24V = 2.5A 60W Max. For LED modules use only www.bokedriver.com MADE IN CHINA		<b>OUTPUT</b> <input type="radio"/> V+ <input type="radio"/> V- <input type="radio"/> VCC <input type="radio"/> GND <input type="radio"/> DIM
	tc:90°C ta:60°C BOKE Drivers Co.,Ltd. Address:2nd and 3rd Floor, No.51, Xihuan 5th Road, South District, 528455 Zhongshan City, Guangdong, CHINA		

<b>INPUT</b> <input type="radio"/> ACL <input type="radio"/> ACN <input type="radio"/> DA <input type="radio"/> DA <input type="radio"/> DA <input type="radio"/> DA 	<b>BOKE Dimmable Constant Voltage LED Driver</b> <b>MODEL: BK-DGV060-48V0D</b> INPUT: 200-240V ~ 0.35A Max. 50/60Hz λ: 0.95 OUTPUT: 48V = 1.2A 57.6W Max. For LED modules use only www.bokedriver.com MADE IN CHINA		<b>OUTPUT</b> <input type="radio"/> V+ <input type="radio"/> V- <input type="radio"/> VCC <input type="radio"/> GND <input type="radio"/> DIM
	tc:90°C ta:60°C BOKE Drivers Co.,Ltd. Address:2nd and 3rd Floor, No.51, Xihuan 5th Road, South District, 528455 Zhongshan City, Guangdong, CHINA		

DGV100

<b>INPUT</b> <input type="radio"/> ACL <input type="radio"/> ACN <input type="radio"/> DA <input type="radio"/> DA <input type="radio"/> DA <input type="radio"/> DA 	<b>BOKE Dimmable Constant Voltage LED Driver</b> <b>MODEL: BK-DGV100-24V0D</b> INPUT: 200-240V ~ 0.65A Max. 50/60Hz λ: 0.95 OUTPUT: 24V = 4.2A 100W Max. For LED modules use only www.bokedriver.com MADE IN CHINA		<b>OUTPUT</b> <input type="radio"/> V+ <input type="radio"/> V- <input type="radio"/> VCC <input type="radio"/> GND <input type="radio"/> DIM
	tc:95°C ta:60°C BOKE Drivers Co.,Ltd. Address:2nd and 3rd Floor, No.51, Xihuan 5th Road, South District, 528455 Zhongshan City, Guangdong, CHINA		

<b>INPUT</b> <input type="radio"/> ACL <input type="radio"/> ACN <input type="radio"/> DA <input type="radio"/> DA <input type="radio"/> DA <input type="radio"/> DA 	<b>BOKE Dimmable Constant Voltage LED Driver</b> <b>MODEL: BK-DGV100-48V0D</b> INPUT: 200-240V ~ 0.65A Max. 50/60Hz λ: 0.95 OUTPUT: 48V = 2.09A 100W Max. For LED modules use only www.bokedriver.com MADE IN CHINA		<b>OUTPUT</b> <input type="radio"/> V+ <input type="radio"/> V- <input type="radio"/> VCC <input type="radio"/> GND <input type="radio"/> DIM
	tc:95°C ta:60°C BOKE Drivers Co.,Ltd. Address:2nd and 3rd Floor, No.51, Xihuan 5th Road, South District, 528455 Zhongshan City, Guangdong, CHINA		

DGV150

<b>INPUT</b> <input type="radio"/> ACL <input type="radio"/> ACN <input type="radio"/> DA <input type="radio"/> DA <input type="radio"/> DA <input type="radio"/> DA 	<b>BOKE Dimmable Constant Voltage LED Driver</b> <b>MODEL: BK-DGV150-24V0D</b> INPUT: 200-240V ~ 1A Max. 50/60Hz λ: 0.95 OUTPUT: 24V = 6.25A 150W Max. For LED modules use only www.bokedriver.com MADE IN CHINA		<b>OUTPUT</b> <input type="radio"/> V+ <input type="radio"/> V- <input type="radio"/> VCC <input type="radio"/> GND <input type="radio"/> DIM
	tc:90°C ta:60°C BOKE Drivers Co.,Ltd. Address:2nd and 3rd Floor, No.51, Xihuan 5th Road, South District, 528455 Zhongshan City, Guangdong, CHINA		

<b>INPUT</b> <input type="radio"/> ACL <input type="radio"/> ACN <input type="radio"/> DA <input type="radio"/> DA <input type="radio"/> DA <input type="radio"/> DA 	<b>BOKE Dimmable Constant Voltage LED Driver</b> <b>MODEL: BK-DGV150-48V0D</b> INPUT: 200-240V ~ 1A Max. 50/60Hz λ: 0.95 OUTPUT: 48V = 3.12A 150W Max. For LED modules use only www.bokedriver.com MADE IN CHINA		<b>OUTPUT</b> <input type="radio"/> V+ <input type="radio"/> V- <input type="radio"/> VCC <input type="radio"/> GND <input type="radio"/> DIM
	tc:90°C ta:60°C BOKE Drivers Co.,Ltd. Address:2nd and 3rd Floor, No.51, Xihuan 5th Road, South District, 528455 Zhongshan City, Guangdong, CHINA		

**Optional accessories**

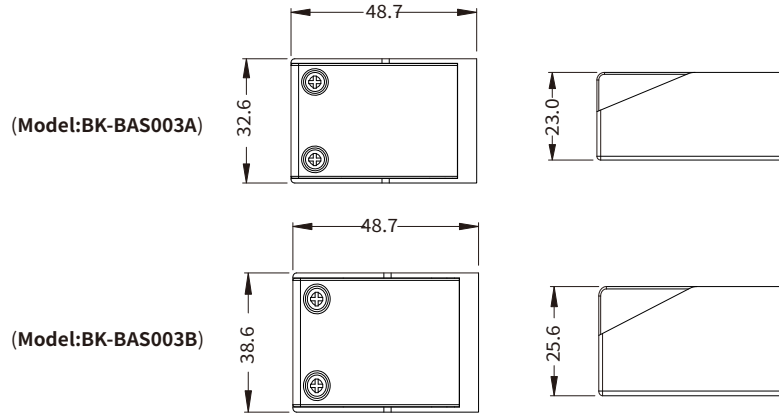
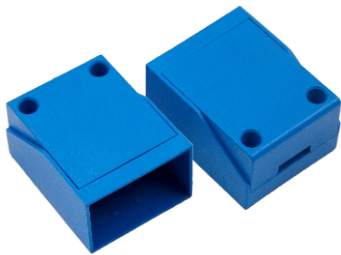

Remark: BK-BAS003A apply to DGV036/DGV060/DGV100  
 BK-BAS003B apply to DGV150

**Unit:mm**

**Installation diagram of accessories**

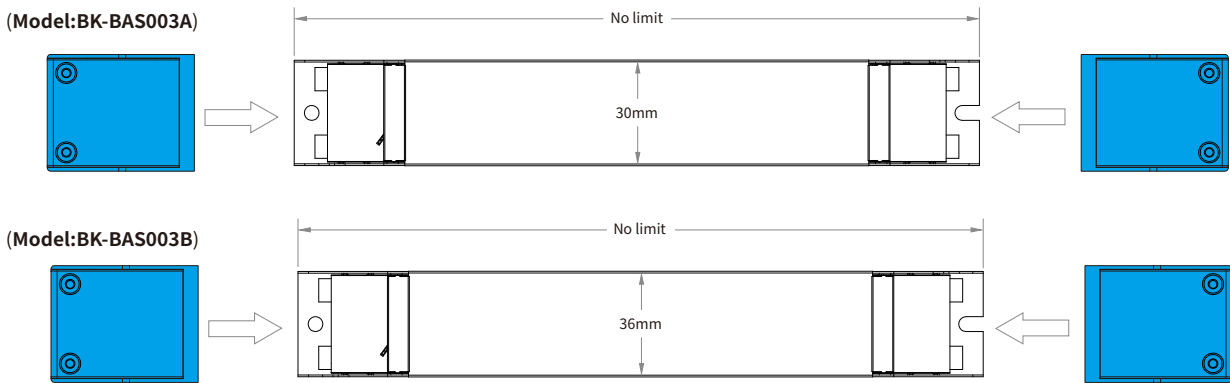

**DALI dimming application**

**Wiring diagram**



**Switch to the DALI dimming mode**

- After installation according to the wiring diagram of DALI dimming application, the driver will automatically switch to the DALI control mode after receiving any DALI command.

**Remarks:**

- Standard DALI control line voltage range: 9.5V to 22.5V ,type 16V.
- The two DALI control lines polarity-reversible.
- Max. 64 DALI drivers per DALI control line.
- The maximum distance length of the DALI control line is 300m at 2×1.5mm<sup>2</sup>.
- DALI bus can be wired together with any mains voltage cables, but separate wiring is recommended.
- The configuration parameters of the driver can be set through the DALI configuration tool or DALI application controller during installation, such as setting device address, group address, power-on level, bus-failure level, scene level, fade time, dimming curve, etc.

Please refer to the table below

Cable size	Distance
2×0.50mm <sup>2</sup>	max.100m
2×0.75mm <sup>2</sup>	max.150m
2×1.00mm <sup>2</sup>	max.200m
≥2×1.50mm <sup>2</sup>	max.300m

**Power-on level :**

When the driver is in DALI-2 dimming mode, the factory default level after each power-on is the brightest.

The power-on level can be set through the DALI configuration tool or DALI application controller during installation, and can be set to memory or fixed any brightness (such as off, darkest, 50%, etc.).

Note: The recommended setting for the default factory power-on level of the DALI-2 driver is the brightest in the DALI-2 standard.

**Dimming curve**

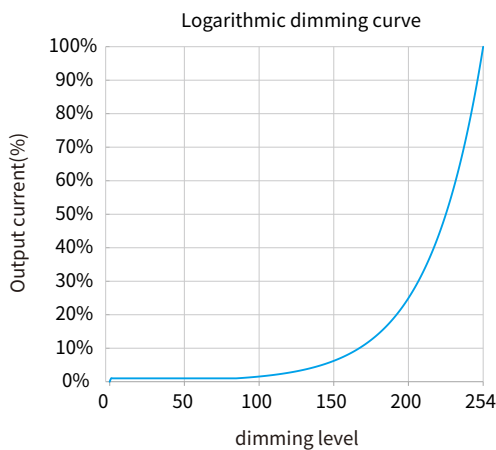

Remarks: The dimming curve can be selected by DALI configuration. The default is logarithmic dimming curve.

**pushDIM dimming application**

**Wiring diagram**

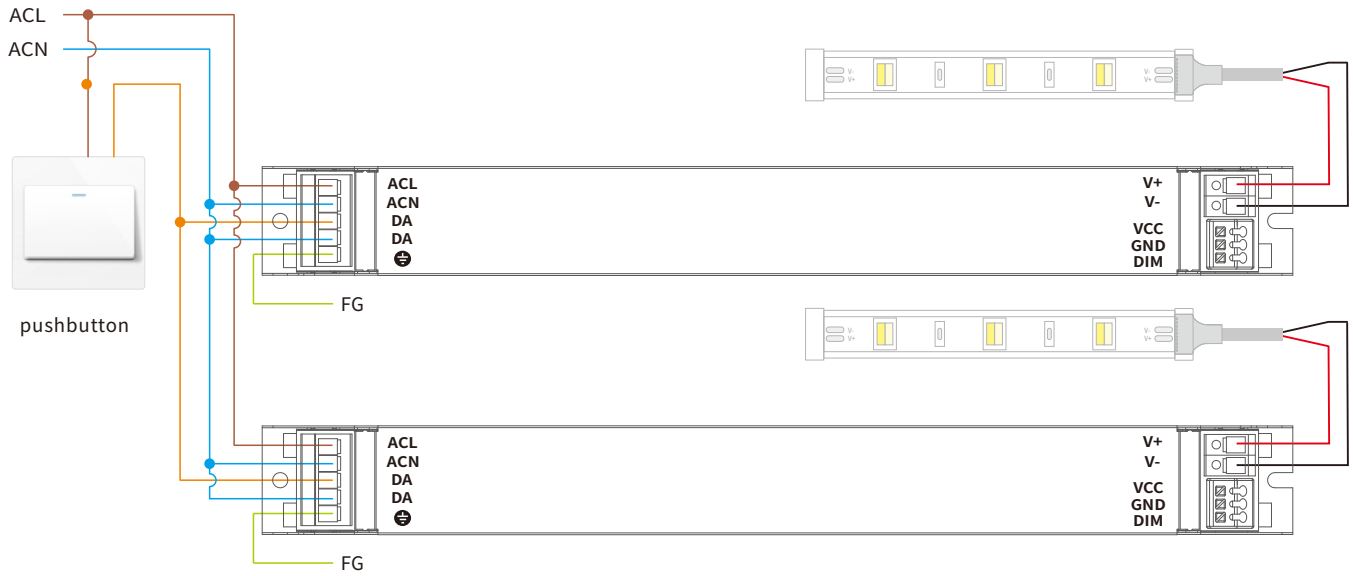

**Switch to the pushDIM dimming mode**

After installation according to the wiring diagram of pushDIM dimming application, long press the pushbutton 3 times ,then the driver will automatically switch to the pushDIM dimming mode.

**Remarks:**

Max. 50 drivers per pushDIM control line.

Turn on or turn off:short press pushbutton for 0.2-1s.

Dimming: long press pushbutton for 1-5s.

Power on status: after power on,the light state will be the same as the lighting on state.

If the light is on before power on,the light will be on after power on again,brightness will be the same as the last lighting on brightness.

If the light is off before power off,the light will be off after power on again,short press the pushbutton,then the light will be on,the brightness will be the same as the last brightness.

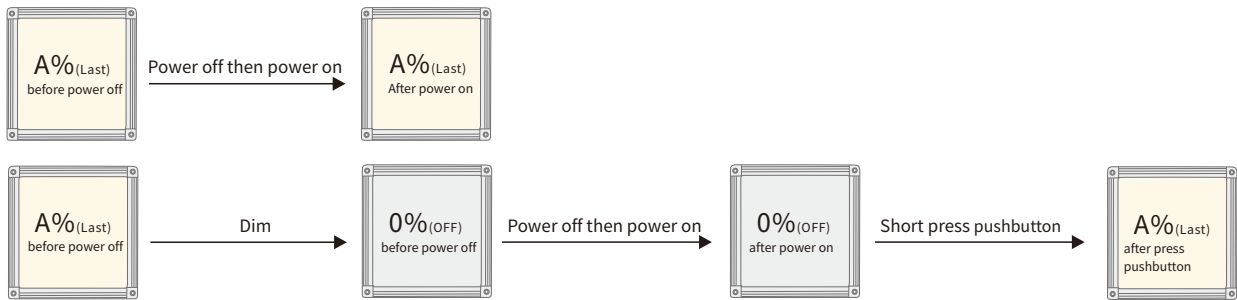

**Multiple lights synchronize control operation**

method 1:

Step 1:long press the pushbutton,confirm each light is on.

Step 2:short press the pushbutton,confirm each light is off.

Step 3:long press the pushbutton,confirm each light is from darkest to brightest and all the lights are synchronous.

method 2:

- Long press the pushbutton 15s,all lights output to the brightest state.

## 1-10V/10V PWM dimming application

### Wiring diagram

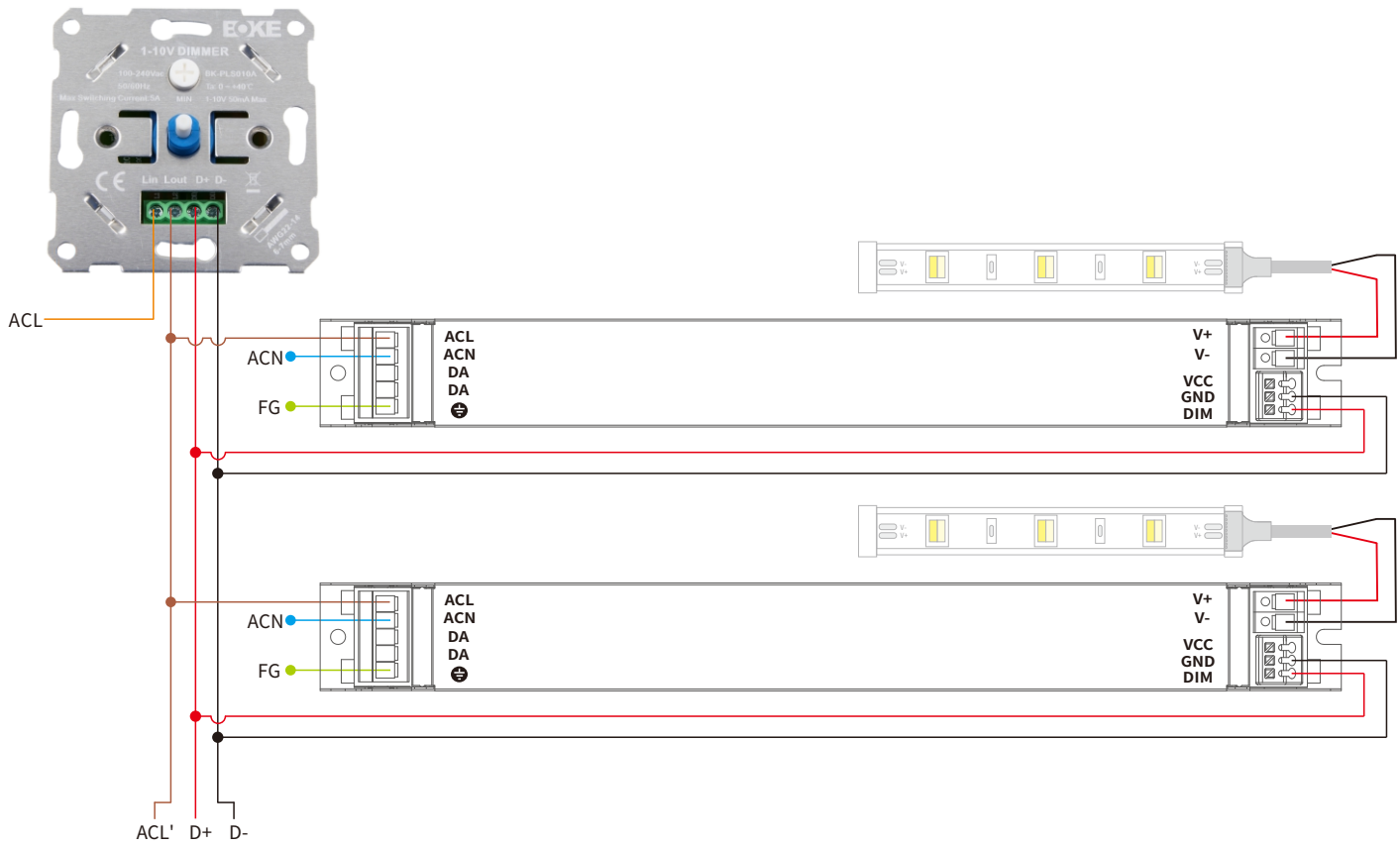

### Switch to the 1-10V / 10V PWM dimming mode

- Method 1: After installation according to the wiring diagram of the 1-10V / 10V PWM dimming application, adjust the dimmer to the minimum and then to the maximum, the driver will automatically activate the 1-10V control mode.
- Method 2: Short-circuit the DIM+ and DIM- ports for 2s, the driver will automatically activate the 1-10V control mode.

### Remarks

- Dimming interface characteristics: 0.9V and below are closed, 1V is the darkest, 10V is the brightest, 1-10V is the dimming range.
- The dimming interface distinguishes between positive and negative, DIM+ is positive, DIM- is negative, please do not reverse.
- Dimming interface does not support voltage access higher than 15V, otherwise it will cause damage to the internal components.
- When the dimming interface is open, the driver outputs the maximum current. When the interface is short-circuited, the current output is closed.
- When multiple synchronous dimming is required, the positive poles of the dimming interface of each driver are connected together, and the negative poles are connected together.
- Support passive dimmer or isolated active dimmer dimming, does not support non-isolated active dimmer dimming.
- In general, it is recommended that the number of mounted drives does not exceed 30pcs, and the wiring length does not exceed 100m.
- It is recommended that the dimming wires should not be lower than the 22AWG wire.
- Do not put the dimming wires with high voltage or interference sources. If it is unavoidable, please use the shielded wires.
- If you need a drive with 0-10V dimming characteristics, please contact BOKE.

### Dimming curve

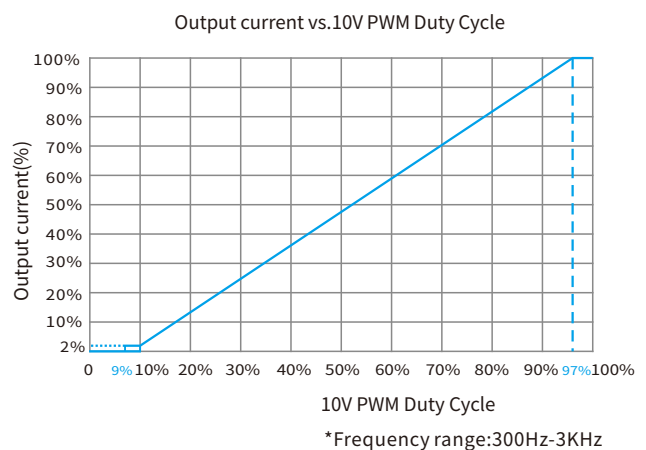
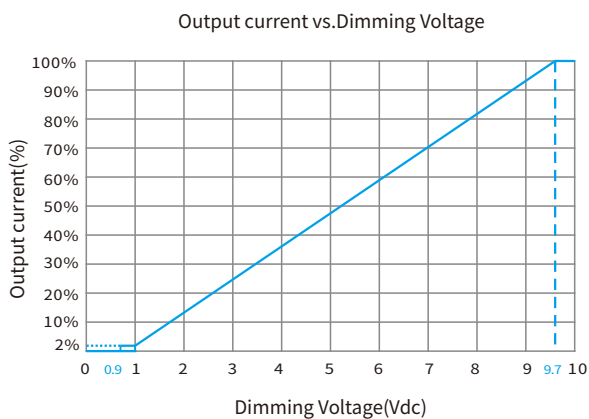

## 150K potentiometer dimming application

### Wiring diagram

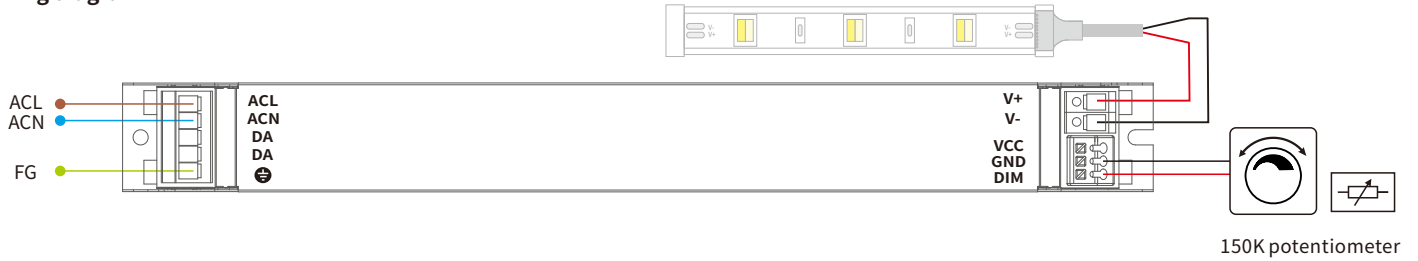

### Remarks

- In the 150K potentiometer dimming mode, the potentiometer can only be connected to one driver.

### Dimming curve

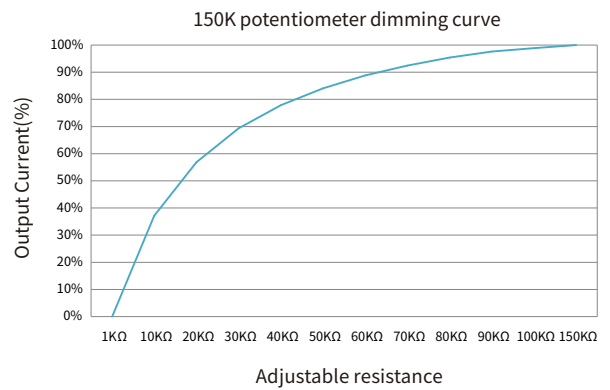

## 1-10V/10V PWM+12V dimming application

### Wiring diagram



### Electrical description

VCC: +12VDC ± 5%, 100mA MAX  
 PDIM: Voltage: 3.3-10V  
 Frequency range: 300hz-3khz  
 Phase position: positive logic  
 Duty cycle: 0%(OFF), 10%(darkest)~100%(brightest)

### Typical applications

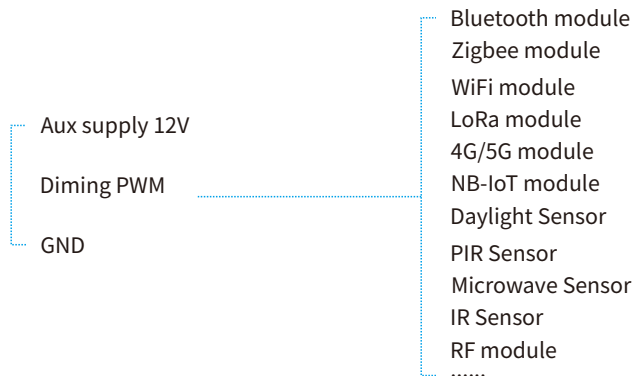

### Dimming curve

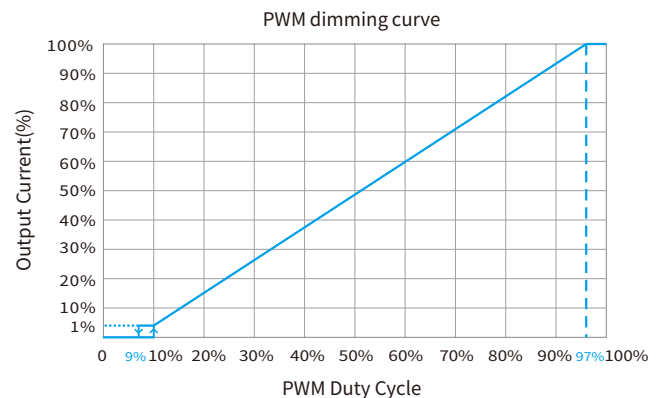

**Mechanical Specification**

Size(Excluding accessories)

Unit:mm

DGV036

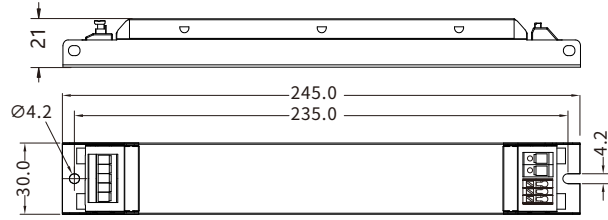

DGV060

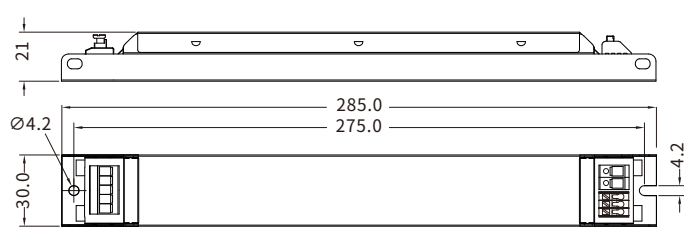

DGV100

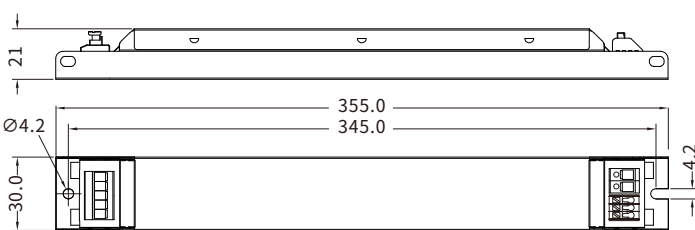

**INPUT**

Numbering	function	colour
1	ACL	orange
2	ACN	orange
3	DA	grey
4	DA	grey
5	FG	grey

Input wire

0.75-1.5mm<sup>2</sup>

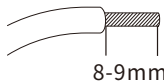

DGV150

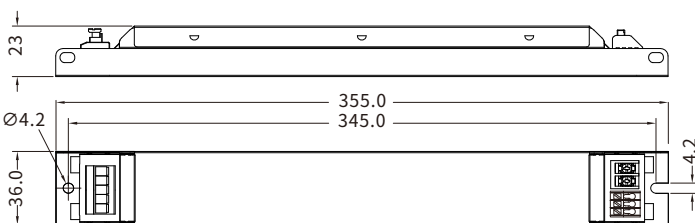

**INPUT**

Numbering	function	colour
1	ACL	orange
2	ACN	orange
3	DA	grey
4	DA	grey
5	FG	grey

Input wire

0.75-1.5mm<sup>2</sup>

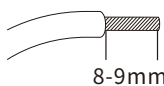

**Mechanical Specification**

Size(Include accessories)

Unit:mm

DGV036

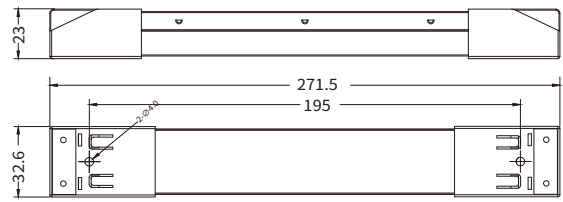

DGV060

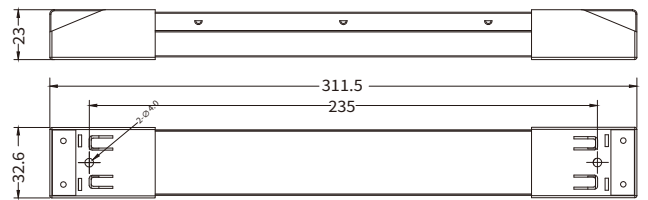

DGV100

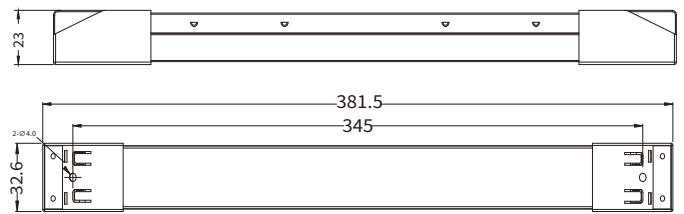

**OUTPUT**

Numbering	function	colour
1	V+	red
2	V-	black

Output wire  
0.75-2.5mm<sup>2</sup>

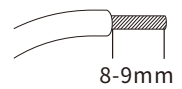

**DIMMING**

Numbering	function	colour
1	VCC	red
2	GND	black
3	DIM	red

Dimming wire  
0.5-1.0mm<sup>2</sup>

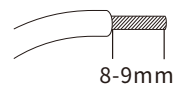

DGV150

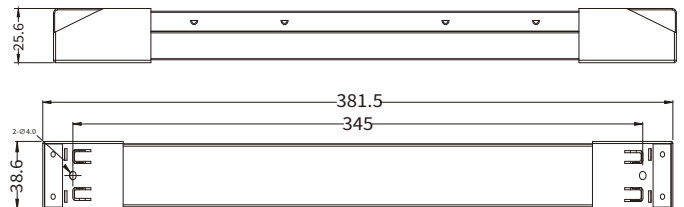

**OUTPUT**

Numbering	function
1	V+
2	V-

Output wire

1.5-2.0mm<sup>2</sup>

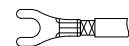

**DIMMING**

Numbering	function	colour
1	VCC	red
2	GND	black
3	DIM	red

Dimming wire  
0.5-1.0mm<sup>2</sup>

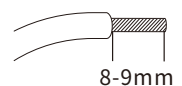

**Cold-pressed terminal reference**

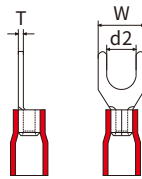
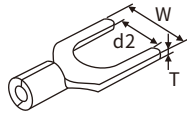

Cold-pressed terminal (bare part)

Cold-pressed terminal (Insulating part)

Product model	Position	Cable cord diameter	Cold-pressed Terminal			
			Model reference	Diameter		
				Inside diameter(d2)	Outside diameter(W)	Thickness(T)
DGV150	Output	0.2-0.5mm <sup>2</sup>	RNB0.5-3.2	3.2mm	5mm	0.5mm
		0.5-1.5mm <sup>2</sup>	SNB1.25-3.2/SV1.25-3		5.7mm	0.7mm
		1.5-2.5mm <sup>2</sup>	SNB2-3.2/SV2-3			0.8mm

**Installation note**

**Hot plug-in**

- Hot plug-in is not supported due to residual output voltage of > 0 V.

**Wiring guidelines**

- All connections must be kept as short as possible to ensure good EMI behaviour.
- Mains leads should be kept apart from LED Driver and other leads (ideally 5 – 10 cm distance)
- Max. length of output wires is 2 m.
- Incorrect wiring can damage LED modules.

**Installation requirements**

- The driver should be installed in a dry, acid-free, oil-free, fat-free environment.
- The installation ambient temperature of the drive shall not exceed the value of Ta at any time.
- The temperature of the mounting surface of the driver should be lower than 40°C
- The driver should keep a certain distance from the heating stuff (such as the luminaire radiator).
- If the driver is used externally (it needs to be used with the accessories), the installation of the driver should also meet the following conditions:
  - 1.The driver should be a certain distance between the drivers, as shown in Figure 1.
  - 2.The driver keeps a certain distance from surrounding objects, as shown in Figure 2.
  - 3.Two power outputs cannot be connected in parallel.

**Mounting screw specifications and torque**

- Max. torque at the clamping screw: 0.5 Nm / M4

**Replace LED module**

1. Mains off
2. Remove LED module
3. Wait for 5 seconds
4. Connect LED module again

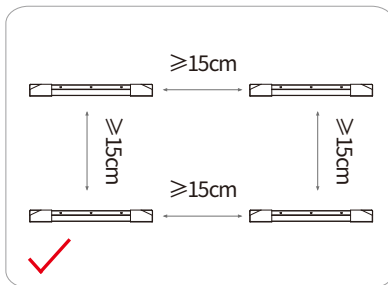
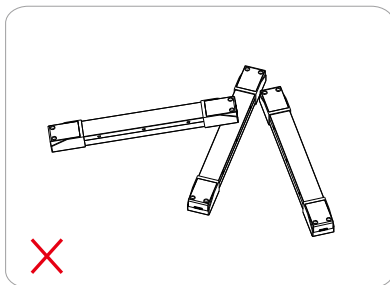

Figure 1

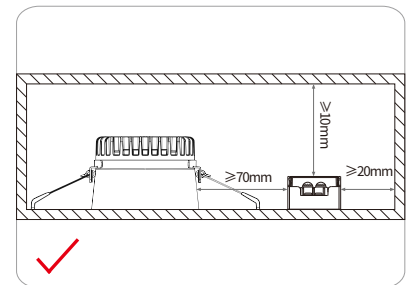

Figure 2

**Packaging**

**Optional 1: factory default**



Product

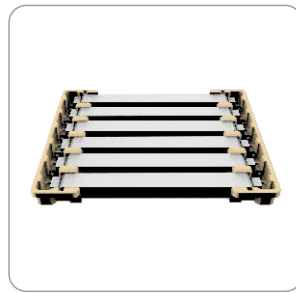

Paper tray



7pcs\*6layer=42pcs/CTN  
 7pcs\*5layer=35pcs/CTN  
 7pcs\*4layer=28pcs/CTN  
 6pcs\*4layer=24pcs/CTN

Model	Product size	Weight	Paper tray	Carton size	Qty/carton	N.W	G.W
DGV036	L245*W30*H21mm	168g	L340*W75*H29mm	L355*W285*H205mm	42pcs	7.06kg	8.66kg
DGV060	L285*W30*H21mm	248g	L340*W75*H29mm	L355*W325*H170mm	35pcs	8.68kg	10.0kg
DGV100	L355*W30*H21mm	307g	L340*W75*H29mm	L395*W355*H140mm	28pcs	8.60kg	9.75kg
DGV150	L355*W36*H23mm	415g	L340*W75*H33mm	L395*W355*H160mm	24pcs	9.96kg	11.2kg

**Optional 2:**



Product

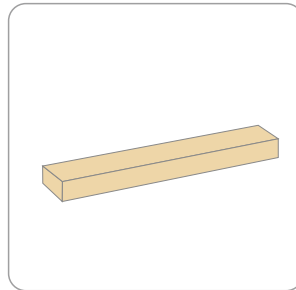

Packaging



8pcs\*5layer=40pcs/CTN  
 7pcs\*5layer=35pcs/CTN  
 9pcs\*3layer=27pcs/CTN

Model	Product size	Weight	Packaging size	Carton size	Qty/carton	N.W	G.W
DGV036	L245*W30*H21mm	168g	L280*W40*H30mm	L345*W300*H175mm	40pcs	6.72kg	7.99kg
DGV060	L285*W30*H21mm	248g	L320*W40*H30mm	L345*W300*H175mm	35pcs	8.68kg	10.5kg
DGV100	L355*W30*H21mm	307g	L390*W40*H30mm	L410*W285*H155mm	27pcs	8.29kg	10.2kg
DGV150	L355*W36*H23mm	415g	L390*W43*H30mm	L410*W285*H155mm	27pcs	11.21kg	13.3kg

**Additional information**

1. The life and MTBF of the product are for reference only, and do not represent a warranty statement.
2. For more information, please send an email to [info@bokedriver.com](mailto:info@bokedriver.com).

**Packaging**

**Accessories**

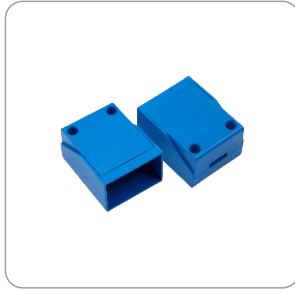

End cap + screws



100 sets/CIN

Model	Product size	Weight	Carton size	Qty/carton	N.W	G.W
BAS003A	L48.7*W32.6*H23mm	22g	L450*W350*H180mm	100 sets	2.2kg	2.7kg
BAS003B	L48.7*W38.6*H25.6mm	27g	L450*W350*H180mm	100 sets	2.7kg	3.2kg

**Additional information**

1. The life and MTBF of the product are for reference only, and do not represent a warranty statement.
2. For more information, please send an email to [info@bokedriver.com](mailto:info@bokedriver.com).